

TS10 Series Press Hall Button

Product Features

- Non-contact hall sensor or long service life potentiometer test way.
- Designed for Industrial remote control, Dustproof and waterproof with long life.

Application

This series of products is mainly used in industrial throttle switch, used in long distance operation, industrial operation panel analog quantity button.



Technical Information

Electrical parameter

Supply voltage	5.0 ± 0.5Vdc (standard voltage)
Supply current	<9mA
Limit allowable voltage	20Vdc
Reverse limit allowable voltage	-10Vdc
Load resistance	>10KΩ
Linear error of output voltage	<± 2%

Mechanical parameter

Shaking angle	4 ± 0.3mm
Operating mode	Automatic spring reset
Maximum operating force	>300N
Limit location force	>2M
Service life	45g
Weight	1Nm Max

Environmental parameter

Working temperature	-30°C~+70°C
Storage temperature	-40°C~+85°C
Level of protection	IP65 (just for the electrical part)

Dimensions

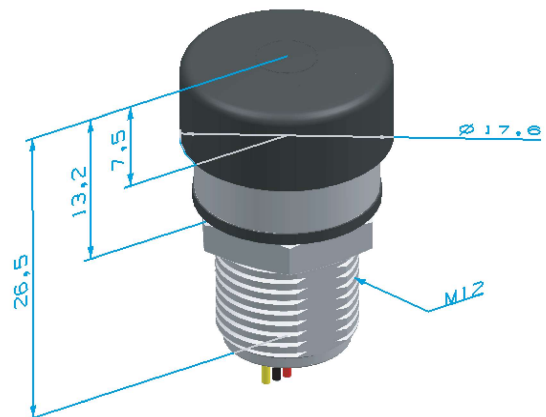

Product Configuration

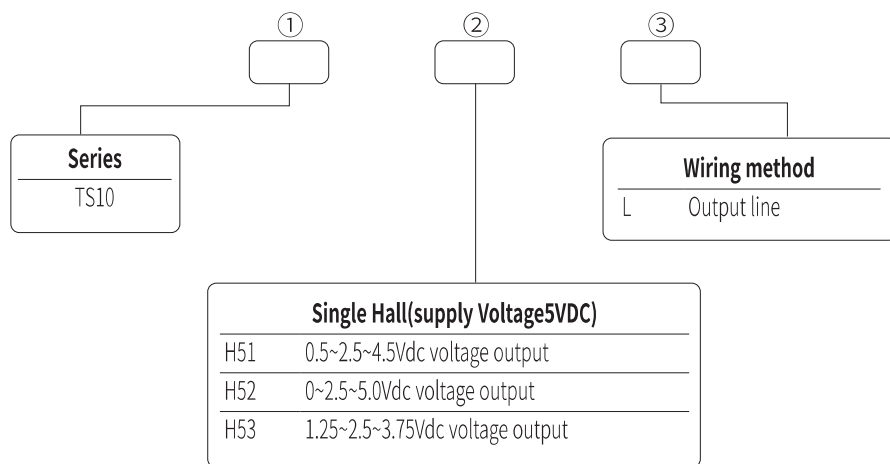

Product Installation

Installation way
Explain: from up to down install button,thread specification M12*1

customer panel

Customer installation diagram

Installation panel

Customer panel opening diagram

Electrical Connections

Direct outlet

Line colour	Function
Red	5V
Black	0V
Yellow	OUT